

# WALL OR WINDOW EXTRACT FANS

## HCM-N Series

Range of axial flow fans designed to exhaust air directly to the outside. All the fans are manufactured from injection moulded plastic and fitted with automatic shutter and single phase 230V-50Hz, class B motor. All the fans are class II insulation and IPX4 rated.



**External shutter**

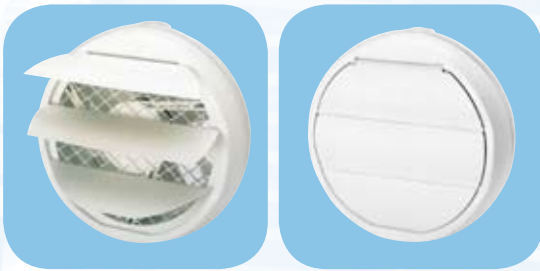

Overpressure shutter

**Safety guards**

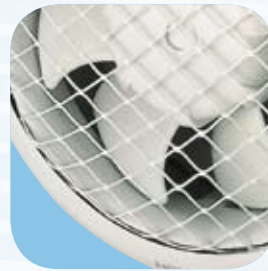

Guards fitted at the inlet and outlet of the fan to prevent the entry of any foreign objects

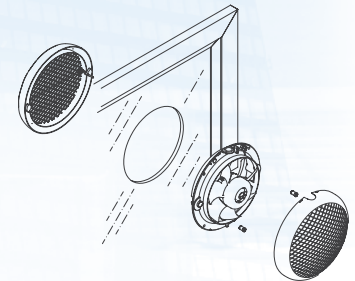

**Mounting in glass**

Maximum diameter (3 to 6 mm)  
 Cut hole diameter (mm)  
 HCM-150 N: 183 to 188  
 HCM-180 N: 220 to 225  
 HCM-225 N: 262 to 267

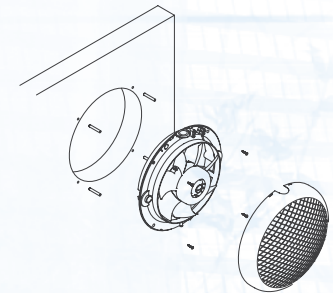

**Mounting in walls**

Cut hole diameter (mm)  
 HCM-150 N: 183 to 188  
 HCM-180 N: 220 to 225  
 HCM-225 N: 262 to 267

**Dimensions (mm)**

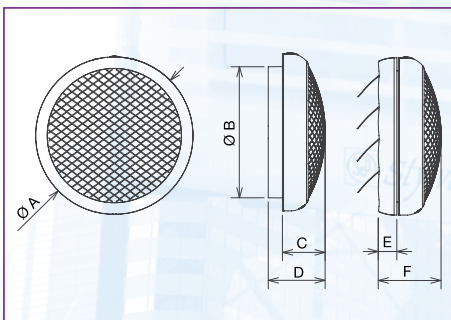

Model	ØA	ØB	C	D	E	F
HCM-150 N	214	174	60	88	35	98
HCM-180 N	255	205	86	120	35	135
HCM-225 N	298	248	89	119	35	125

**Easy installation**

In glass using two screws to fix the inner fan assembly with the outer part.  
 For wall mounted installation using 4 screws to fix the inner fan assembly directly on the wall.

**Accessories**



**REB**  
 Electronic, single phase speed controller

**Technical characteristics**

Model	Speed (r.p.m.)	Maximum absorbed power (W)	Voltage (V) 50 Hz	Maximum airflow (m³/h)	Sound pressure level* (dB(A))	Weight (kg)
HCM-150 N	1900	25	230	400	40	0,9
HCM-180 N	2000	24,8	230	600	41	1,7
HCM-225 N	1700	40	230	900	45	1,8

\* Sound pressure level measured at 1,5m, at the inlet side, in free field.

